



1000-Watt DE HPS Enclosed System

Performance			
Lamp	Number	1	
	Watts	1000W	
InputVolts	120V	240V	
Input Current	9.30A	4.60A	
Input Power	1085W	1055W	
Min Power Factor	0.99		
THD	<10%		
Crest Factor	<1.7		

Physical			
Case Length	579mm	22.79"	
Case Width	236mm	9.29"	
Height	271mm	10.67"	
Weight	6.0kg	13.22lb	

Dimming Type							
Gear	600	750	825	1000	1150	EXT	

1.External control: Master Controller

Protections

- 1.End of Lamp Life(EOL)Protection
- 2.Short circuit protection
- 3.Open circuit protection
- 4.Ignition failure protection
- 5.Thermal protection
- 6.Tree color status LED advanced status indication and status history
- 7.Suitable for Megaphoton Master Controller
- 8.Total control range 50-115%

Installation & Application Notes

- 1.Max. allowable case temperature:75°C/167°F.
- 2.Ambient Temperature:-20...+40°C/-4...+104°F.
- 3.Max. Humidity:95%.
- 4.Ignition voltage is 5kV.
- 5.Remote Mounting: 5 m/16ft.

Performance Requirements:	
Rated mains voltage:	120-240V
Voltage range (+/-10%):	108-264V
Mains frequency:	50/60Hz
Operation frequency :	100-120kHz

Main Dimension

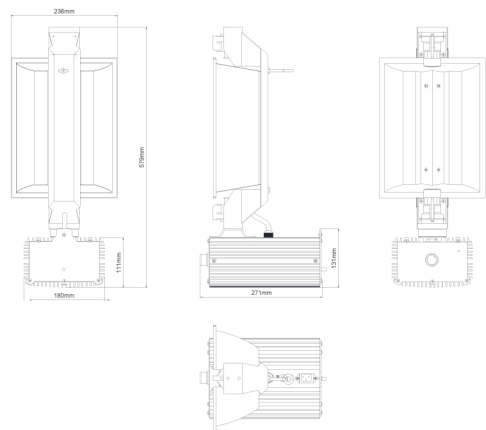

Wiring Diagram

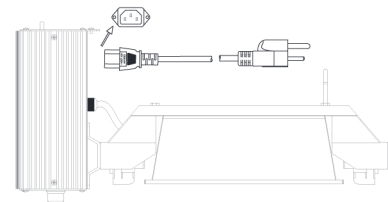

Ballast Case must be Grounded

Tcase max=75°C/167°F

